

Hornady
Accurate. Deadly. Dependable.

Lock-N-Load® AP™ Primer Pocket Swage Tool

ASSEMBLY & PREPARATION

Before using your new swage tool, disassemble and carefully clean the dies, removing the rust preventative. DO NOT disassemble the swage punch assembly (1) as it comes pre-set from the factory. Any commercial solvent or cleaner, like Hornady ONE SHOT® Gun Cleaner and Dry Lube, will suffice. Reassemble the swage die after cleaning.

Cartridge cases should be de-primed and inspected. Discard those with cracks, splits, or other visible defects. Make sure case necks are round. You may need to run an expander through them or full length size the cases before swaging. Primer pockets should be clean.

IMPORTANT: Sort cases by manufacturer and lot number, if possible. Different brands have varying web thicknesses, which can cause swage variation.

INSTRUCTIONS

Install swage plate assembly (5) onto your Lock-N-Load® AP™. You will not need a case retainer spring.

Raise the press ram to the top of its stroke and thread the swage die (7) into station 1 (Fig. A) until it makes contact with the swage plate assembly. Back the swage die off a half turn and tighten the Sure-Loc™ lock ring (3).

Thread the swage stripper die (2) into station 3 (Fig. A) until it makes contact with the swage plate. Tighten the Sure-Loc™ lock ring.

Thread the swage alignment die (6) into station 4 (Fig. A) until it makes contact with the swage plate. Tighten the Sure-Loc™ lock ring.

NOTE: The swage stripper die and swage alignment die must be in contact with the swage plate assembly while the press ram is at the top of the stroke to assure proper function of the swage die without damaging the press.

PARTS

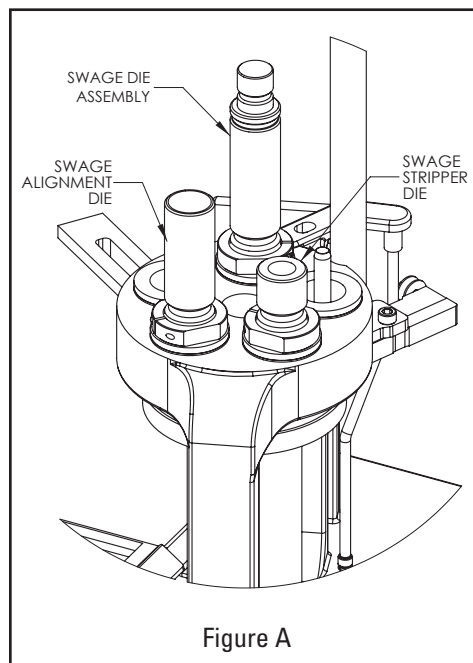
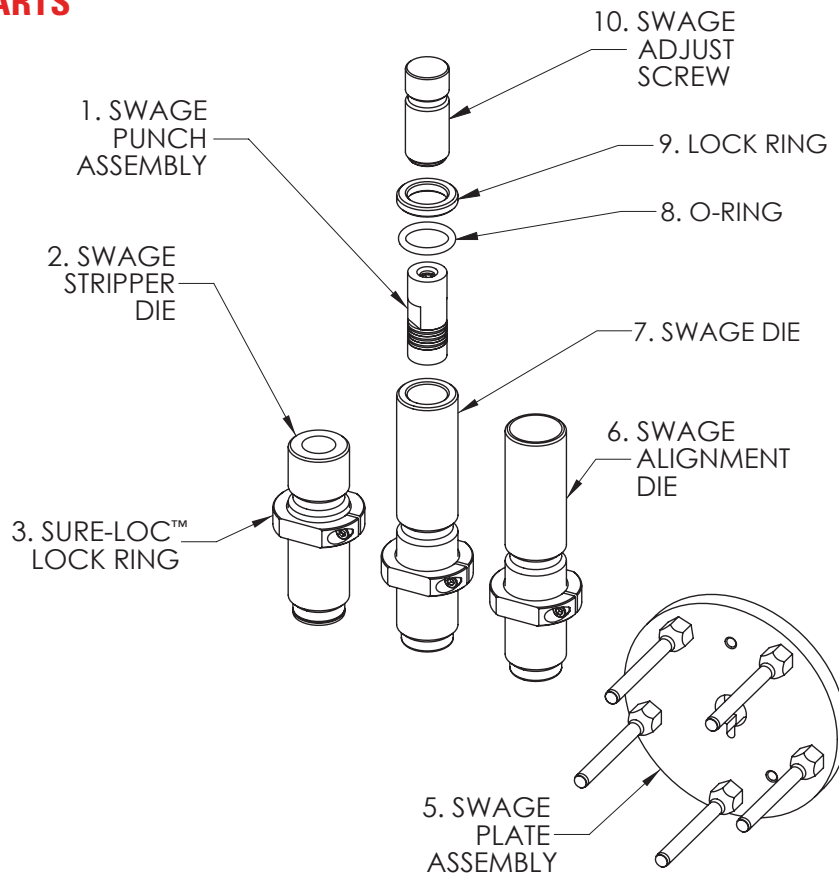

Figure A

Insert a sorted case into the swage alignment die mouth first. Lower the press ram. The case will feed onto the swage plate support stem.

With the swage adjust screw (10) backed out of the swage die, cycle the press until the inserted case enters the swage die.

Thread the swage adjust screw down until you feel resistance. Lower the press ram about 1-inch and thread the swage adjust screw down half a turn. Raise the press ram. You should start to feel the resistance when raising the press ram. At this point, the primer pocket crimp is starting to be swaged.

Adjustment for the proper amount of swage is done by trial and error.

(OVER)

INSTRUCTIONS (CON'T)

Insufficient swage may make primer seating difficult and over-swaging could damage the swage plate support stem or the cartridge case.

NOTE: The Lock-N-Load Primer Pocket Swage is designed to swage the crimp and not the entire primer pocket.

Continue this process, making adjustments in 1/8 turn increments until desired swage is achieved. The swage punch assembly will eject the case from the swage punch. If desired, you can use a small amount of case lube on the swage punch or on the primer pocket.

A properly swaged primer pocket will have a small radius at the edge of the primer pocket (see photo below). It is wise to set the swage for a minimal radius and test by seating a primer in the case. Adjust until enough swage is achieved to seat a primer properly.

NOTE: If using lube, remove it before priming as many lubes will contaminate primers.

Once proper swage is achieved, thread the swage adjust lock ring (9) down onto the o-ring (8) to lock the swage adjust screw position.

At this point, the press is set and ready to swage the pockets. Start the process by cycling the press and inserting sorted, de-primed cases into the swage alignment die (station 4) at the top of the stroke. When the first case reaches the swage die (station 1), it will be swaged. You will feel the cam-over of the press as it's swaging. Continue cycling the press. When the first case reaches the stripper die (station 3), it will be lifted from the swage plate support anvil. When the second case reaches the stripper die, it will push the first case out the top of the die allowing removal (Fig. B).

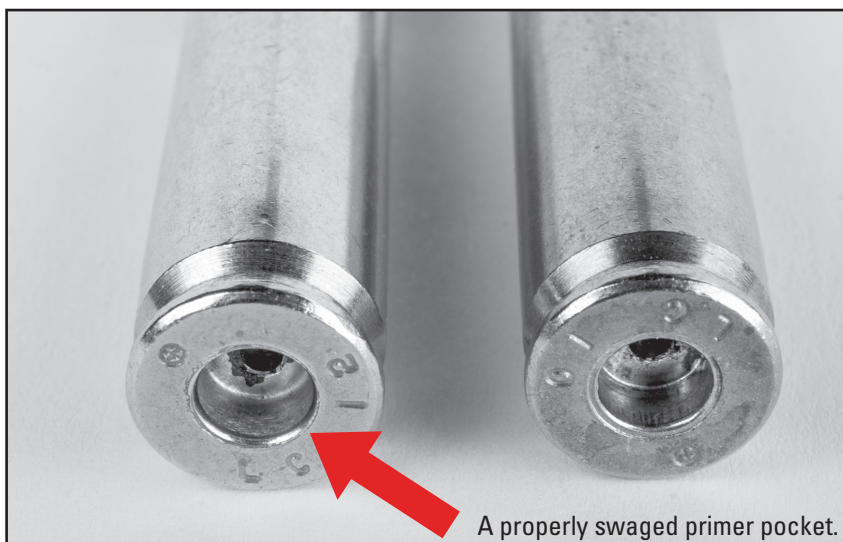
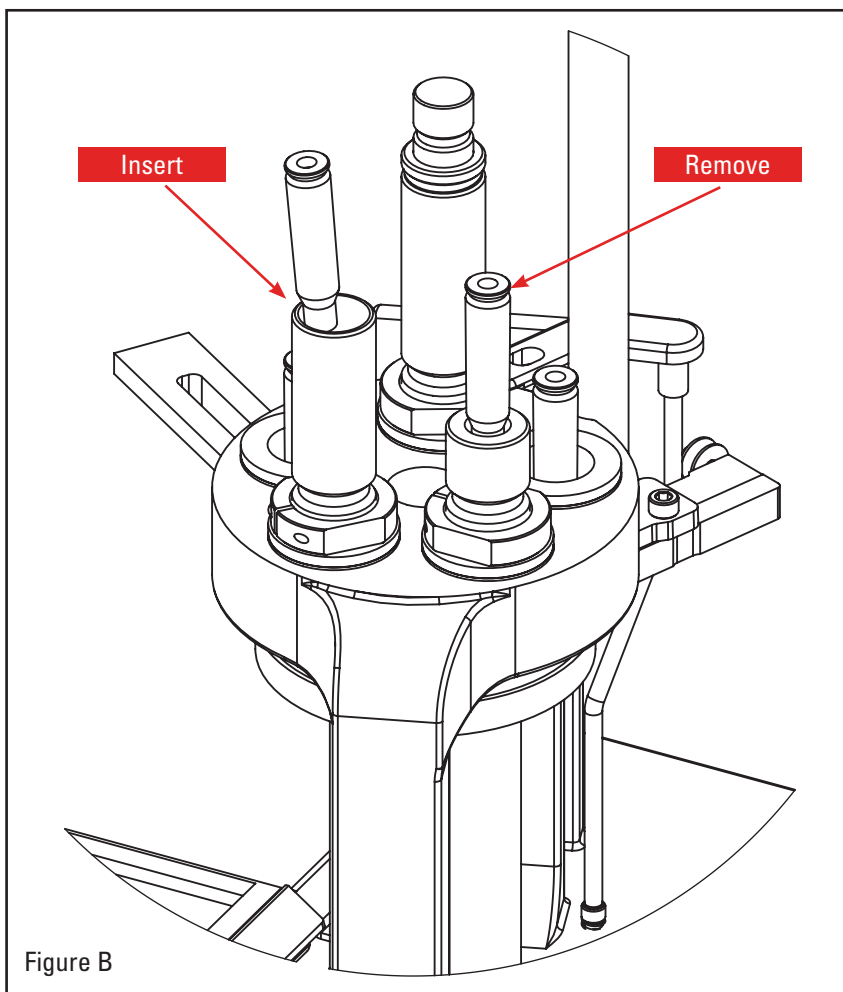

Hornady
Accurate. Deadly. Dependable.